

1-1-2004

Population genetic structure of the prairie skink (*Eumeces septentrionalis*): Nested clade analysis of post Pleistocene populations

Gregory S. Fuerst
University of North Dakota

Christopher C. Austin
University of North Dakota

Follow this and additional works at: https://digitalcommons.lsu.edu/biosci_pubs

Recommended Citation

Fuerst, G., & Austin, C. (2004). Population genetic structure of the prairie skink (*Eumeces septentrionalis*): Nested clade analysis of post Pleistocene populations. *Journal of Herpetology*, 38 (2), 257-268.
<https://doi.org/10.1670/190-03A>

This Article is brought to you for free and open access by the Department of Biological Sciences at LSU Digital Commons. It has been accepted for inclusion in Faculty Publications by an authorized administrator of LSU Digital Commons. For more information, please contact ir@lsu.edu.



Population Genetic Structure of the Prairie Skink (*Eumeces septentrionalis*): Nested Clade Analysis of Post Pleistocene Populations

Authors: Fuerst, Gregory S., and Austin, Christopher C.

Source: Journal of Herpetology, 38(2) : 257-268

Published By: Society for the Study of Amphibians and Reptiles

URL: <https://doi.org/10.1670/190-03A>

BioOne Complete (complete.BioOne.org) is a full-text database of 200 subscribed and open-access titles in the biological, ecological, and environmental sciences published by nonprofit societies, associations, museums, institutions, and presses.

Your use of this PDF, the BioOne Complete website, and all posted and associated content indicates your acceptance of BioOne's Terms of Use, available at www.bioone.org/terms-of-use.

Usage of BioOne Complete content is strictly limited to personal, educational, and non - commercial use. Commercial inquiries or rights and permissions requests should be directed to the individual publisher as copyright holder.

BioOne sees sustainable scholarly publishing as an inherently collaborative enterprise connecting authors, nonprofit publishers, academic institutions, research libraries, and research funders in the common goal of maximizing access to critical research.

Population Genetic Structure of the Prairie Skink (*Eumeces septentrionalis*): Nested Clade Analysis of Post Pleistocene Populations

GREGORY S. FUERST AND CHRISTOPHER C. AUSTIN¹

Biology Department, University of North Dakota, Grand Forks, North Dakota, 58202-9019, USA

ABSTRACT.—We sequenced two regions of the mitochondrial genome, ND4 and d-loop, from 64 *Eumeces septentrionalis* to assess intra- and interspecific population differentiation. We constructed haplotype genealogies for nine *Eumeces septentrionalis septentrionalis* populations in previously glaciated regions and used nested clade analysis to examine the role of vicariance and dispersal in shaping the population structure of *E. s. septentrionalis* in the northern part of its range following Pleistocene paleoclimatological events. In addition, we used DNA sequence data to compare populations of the northern subspecies (*E. s. septentrionalis*) with the southern subspecies (*Eumeces septentrionalis obtusirostris*) to determine whether specific level differentiation is evident. For populations of *E. septentrionalis* in previously glaciated areas, nested clade analyses revealed isolation by distance with restricted gene flow at both haplotype and upper clade levels as the inferred geographical pattern reflecting the lack of overlapping haplotypes in distant populations. These results suggest that colonization of *E. septentrionalis* into previously glaciated areas was from a single source with restricted gene flow. These results do not support past population fragmentation or colonization from multiple, genetically distinct source populations. Parsimony and maximum likelihood phylogenetic analyses showed reciprocal monophyly between northern (*E. s. septentrionalis*) and southern (*E. s. obtusirostris*) subspecies with uncorrected sequence divergence ranging from 6.7–7.0%. These results, combined with the morphological differences found in previous studies, suggest that these allopatric populations are on separate evolutionary trajectories.

Pleistocene climate change has influenced genetic differentiation in North American vertebrate poikilotherms (Phillips, 1994; Hewitt, 1996; Avise, 2000; Burbrink et al., 2000; Austin et al., 2002; Starkey et al., 2003). During Pleistocene climatic oscillations, the spatial distribution of North American flora and fauna changed dramatically, and data on glacial geomorphology and palynology have provided a composite picture of fluctuations in temperature and vegetation composition. As glaciers advanced, they altered habitats and likely isolated many species with broad distributions. These isolated refugia possibly acted to generate genetic diversity via allopatric differentiation of the North American biota (Nelson and Platnick, 1981; Nelson and Rosen, 1981; Humphries and Parenti, 1986). For populations recolonizing formerly glaciated areas, founder events influenced the genetic composition of colonizing populations resulting in loss of allelic diversity (Futuyama, 1998; Avise, 2000).

Two glaciers, the Laurentide and the Cordilleran Ice Sheets, spanned the northern half of the

North American continent during the Pleistocene (Matsch, 1976). The larger of these two glaciers, the Laurentide Ice Sheet, stretched from Nova Scotia and the northeastern United States down into southern Illinois, Indiana, and Ohio during its furthest advance in the Illinoian time period (130,000–300,000 ybp). Subsequent advances occurred about every 1000 years, and the Laurentide Ice Sheet's final advance took place about 15,000 ybp. This advance consisted of two lobes with one extending into the northern half of Indiana and Ohio, and the other extending south into South Dakota and Iowa (Fig. 1A; Holman, 1992).

Advancement of the Laurentide ice sheet produced a variety of topographical changes to the land. This ice sheet is believed to have been 2–3 km thick, and its tremendous mass molded the contours of the land as it advanced (Flint, 1971). As the Laurentide Ice Sheet pushed its way southward about 20,000 years ago, rivers flowing northward were blocked by the advancing glacier. The result was the flooding of the surrounding land to form Lake Agassiz (Flint, 1971; Matsch, 1976). Sediments carried by these rivers into Lake Agassiz today constitute a large portion of the soil structure in the upper Midwest. These sedimentary soils are important microhabitat requirements for many burrowing vertebrates including *Eumeces septentrionalis* (Wheeler

¹ Corresponding Author. Present address: Museum of Natural Science, 119 Foster Hall, Louisiana State University, Baton Rouge, Louisiana 70803, USA; E-mail: ccaustin@lsu.edu

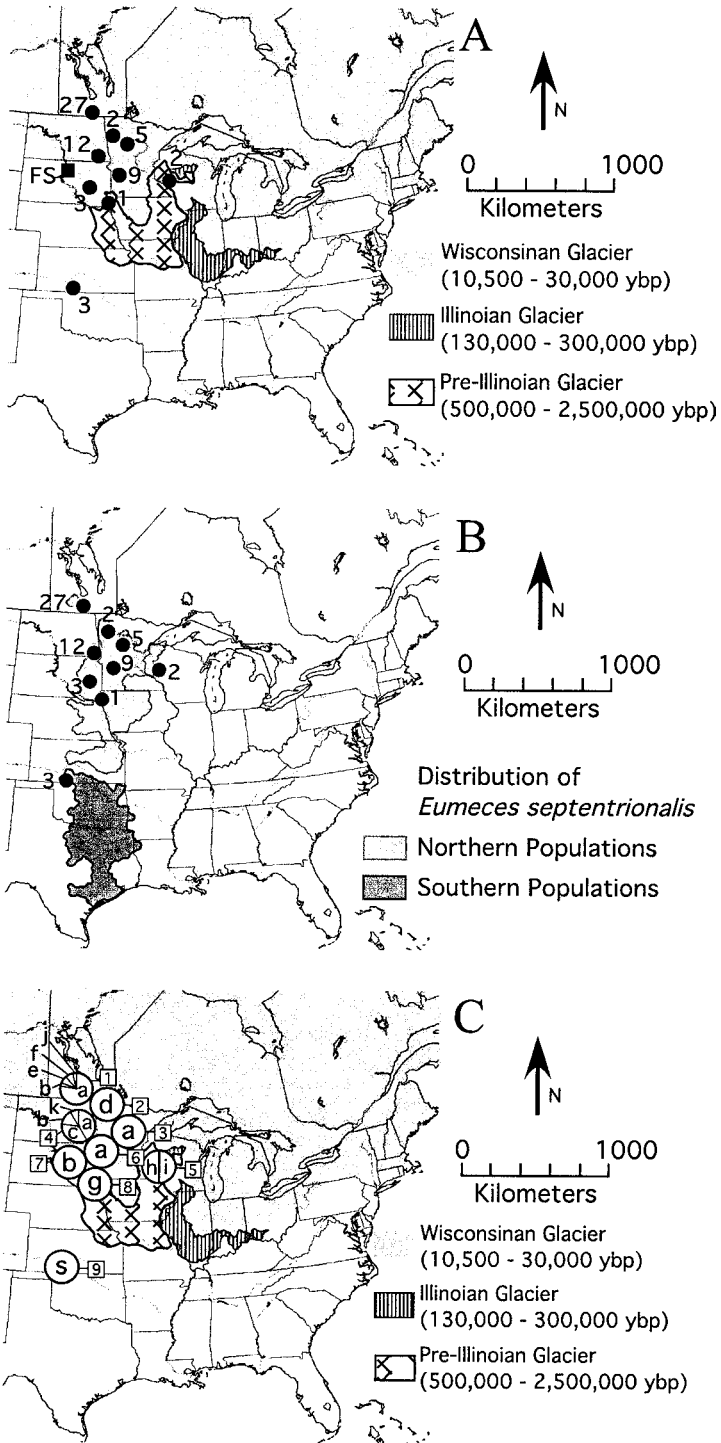

FIG. 1. (A) Maximum extent of the Laurentide Ice Sheet during the last three glaciations as referenced by Holman (1992). The number of individuals sampled at each locality are shown next to closed bullets. Solid square labeled "FS" represents the location of *Eumeces septentrionalis* fossils as reference by Holman (1977). (B) Sampling localities for *E. septentrionalis* across its distribution. (C) Haplotype frequencies as distributed across nine populations of *E. septentrionalis*. Assigned population numbers are shown in boxes.

and Wheeler, 1966). This small scincid lizard requires soft, sandy soils in the northern regions to burrow beneath the freeze line; individuals are reported to burrow as deep as 1.4 m during the winter months (Scott and Sheldahl, 1937; Breckenridge, 1943).

The Prairie Skink (*E. septentrionalis*) provides an excellent opportunity to examine effects of historical Pleistocene climate change because soil requirements and a distribution covering previously glaciated and unglaciated regions directly relate this species to paleoclimatological events. The distribution of *E. septentrionalis* extends from southern Canada to Texas and has two major breaks producing three disjunct populations. The first break is found in a previously glaciated region and separates the Manitoba population from contiguous populations in North Dakota, South Dakota, Minnesota, Wisconsin, Nebraska, Iowa, and Kansas. The second break separates two of the currently defined subspecies, *Eumeces septentrionalis septentrionalis* and *Eumeces septentrionalis obtusirostris*, and occurs along the Arkansas River Valley in Kansas (Fig. 1B, Conant and Collins, 1998). These subspecific designations are based on morphological differentiation (Taylor, 1935) and allopatry (Collins, 1993; Conant and Collins, 1998). The genetic basis of the differentiation of these populations, however, has never been examined. Current taxonomy recognizes a third subspecies, *Eumeces septentrionalis pallidus* (Crother, 2000). This subspecies was originally described from several localities in Palo Pinto County, Texas by Smith and Slater (1949), however, it has not been referenced in the literature within the last 40 years.

We sequenced two regions of the mitochondrial genome, ND4 and d-loop, from 64 *E. septentrionalis* to address questions of intra and interspecific population differentiation. We constructed robust haplotype genealogies for nine *E. s. septentrionalis* populations in previously glaciated regions and used nested clade analysis to examine the role of vicariance and dispersal in shaping the population structure of *E. s. septentrionalis* in the northern part of its range. In addition, we used DNA sequence data to compare populations of the northern subspecies (*E. s. septentrionalis*) with the southern subspecies (*E. s. obtusirostris*) to determine whether specific level differentiation is evident.

MATERIALS AND METHODS

Field Methods.—Sixty-four tissue samples were collected from individuals in Canada, North Dakota, South Dakota, Minnesota, Wisconsin, and Kansas (April to September 2001 and May to September 2002). In addition, tissues were collected from *Eumeces obsoletus* for use as an outgroup (Appendix 1).

Lizards found under natural cover (logs, leaf litter) or human debris cover (boards, plywood, garbage) were hand captured. This method is most effective for capturing skinks because of their secretive nature (Nelson, 1963; Bredin, 1981; Lang, 1982). In areas with little or no obvious refuge sites for skinks, plywood boards (0.6–1.2 × 30 × 120 cm) were placed in areas depending on availability of direct sunlight for basking and moist, sandy soil. *Eumeces septentrionalis* require loose soil such as sand for cover on a daily basis and to allow burrowing beneath the freeze line during winter months. Of the total tissues collected, 27 came from an isolated population in Canada, 12 came from southeastern North Dakota, 16 came from populations in Minnesota, two came from Wisconsin, four came from South Dakota, and three were collected from the currently recognized southern subspecies, *E. s. obtusirostris* (Fig. 1B, Appendix 1). In some cases, tissues were taken in the form of tail clips, and animals were released on site. For liver samples and for historical record, several animals from each site were taken as vouchers and are deposited in the collection at the Museum of Natural Science, Louisiana State University (LSUMZ). All tissues were individually placed in vials of 95% ethanol and labeled with date, locality information, and a unique field identification number.

DNA Isolation, Amplification, and Sequencing.—We examined the genetic diversity in two mitochondrial (mtDNA) markers, ND4 and d-loop. In vertebrates, d-loop is a noncoding fragment of the mitochondrial genome. This excludes it from coding constraints and allows for the accumulation of base substitutions and insertions and deletions (indels). ND4 has been found to be a reliable tracer of evolutionary history (Russo et al., 1996; Zardoya and Meyer, 1996), and previous studies have found it useful at similar taxonomic levels (Benabib et al., 1997; Forstner et al., 1998; Richmond and Reeder, 2002; Keogh et al., 2003). DNA was isolated from tissues with a 25 μ l Proteinase K digestion for at least three hours using standard protocols (Qiagen Inc., Valencia, CA), and final extraction concentrations of DNA were stored in AE Buffer at -70°C . Based on gel band intensity compared with a known concentration of λ Hind III ladder, extracted DNA was then diluted to 20 ng DNA per μ l of water.

Double-stranded polymerase chain reaction (PCR; Palumbi, 1996) was used to amplify an 895 base pair (bp) fragment of ND4, and an ~844 bp fragment of d-loop. Primers used for amplification are listed in Table 1. The products amplified from these primers correspond to positions 10768–11663 (ND4) and 16348–17192 (d-loop) of the entire mtDNA of *Eumeces egregius* (Kumazawa and Nishida, 1999). Fifty μ l PCR reactions were used to amplify ND4 and d-loop

TABLE 1. Oligonucleotide primers used for PCR and/or sequencing (asymmetric PCR) reactions. Primers used for PCR and sequencing reactions are labeled "PCR/Seq.," and primers used solely for sequencing reactions are labeled "Seq.," Position numbers reflect the 5' end of each primer with reference to the *Eumeces egregius* mtDNA genome (Kumazawa and Nishida 1999).

Primer name	Marker	Sequence 5'-3'	Position	PCR/Seq.	Source
ND4Gold	ND4	CTTTGACTYCCMAARGCCACGTAGA	10768	PCR/Seq.	Richmond and Reeder, 2002
tleu2c	ND4	TTGACTTTGATCCTTTRAAAGTGAG	11639	PCR/Seq.	Richmond and Reeder, 2002
MCCA313R	d-loop	GGTAGGGGGTTTGTGCGTAAAA	17170	PCR/Seq.	This study
MCCA314R	d-loop	GGGGGTTTGTGCGTAAAAAATGT	17164	Seq.	This study
MCCA320F	d-loop	ATCTACCAATGCTGCTCTCTTG	16348	PCR/Seq.	This study

segments and contained 20 ng template DNA, 5 μ l 10 \times Ex Taq Buffer, 4 μ l dNTP mixture (2.5 mM each), 1 μ l (5 pmol/ μ l) of each primer, and 0.25 μ l Ex Taq. A negative control was used for all PCR reactions, and double-stranded PCR products were amplified using a Hybaid Omni-E thermal cycler programmed as follows: (1) one cycle at 94°C \times 2 min, 55°C \times 45 sec, and 72°C \times 80 sec, (2) 34 cycles at 94°C \times 45 sec, 55°C \times 45 sec, and 72°C \times 1 min, (3) one cycle at 72°C \times 6 min. Amplified products were cleaned using a MO BIO UltraClean PCR Clean-up Kit (MO BIO Lab., Inc., Solana Beach, CA) and used as template for sequencing reactions. Complementary strands of the cleaned, PCR products were individually sequenced on a Hybaid Omni-E thermal cycler using 10 μ l reactions that contained 1.5–3 μ l template, 1 μ l ABI Prism dye-terminators, 1 μ l 5 \times Buffer, and 1 μ l (5 pmol/ μ l) of the primer. Cycle sequencing conditions were as follows: 25 cycles at 96°C \times 10 sec, 50°C \times 5 sec, and 60°C \times 4 min. Products were cleaned using Princeton Separation Centri-Sep Columns (Princeton Separations, Inc., Adelphia, NJ), and sequences were run on an ABI 3100 automated sequencer.

Sequence Alignment.—Sequences were linked and edited using SeqEd v. 1.0.3 (SeqEd v. 1.0.1, 1991 Applied Biosystems, Inc.) and aligned using ClustalX (Thompson et al., 1997). There were no insertion/deletion (indels) events associated with the ND4 dataset, and these data were easily aligned. However, as is common within d-loop, there were several indel events that required gaps to align the sequences. These areas were aligned using a parsimony criteria with the fewest gaps possible. One of the indels within this sequence spanned a 58-bp region of repeated sequence and could not be aligned with confidence. This region was thus removed from all analyses.

A partition homogeneity test implemented in PAUP* did not detect significant heterogeneity between the two mitochondrial regions (see Results). The mitochondrion does not undergo recombination, and it is thus appropriate to think of the circular mitochondrial genome as one evolving unit (i.e., a single locus). ND4 and

d-loop datasets, therefore, were combined for subsequent phylogenetic and nested clade analyses.

Nested Clade Analysis.—Haplotypes were networked using TCS version 1.13 (Clement et al., 2000). This program implements the algorithm described by Templeton (1992), which uses a statistic from neutral coalescent theory (Hudson, 1989). Pairwise distance values are first calculated for all haplotypes, and these values are then used to evaluate the limits of parsimony in constructing networks above the 95% level. A network of the haplotypes is then constructed using these limits. TCS in combination with geographic distance analysis (described below) has been shown to be useful to infer population structure when sequence divergence is low (Routman et al., 1994; Gerber and Templeton, 1996) and has also been used to separate population structure from population history (Templeton et al., 1995; Templeton, 1998).

Networked haplotypes were nested into clades according to the methods given by Templeton et al. (1987) and Templeton and Sing (1993). These methods start at the tips and nest zero step clades (haplotypes) that are one mutational step apart. This process is then repeated with upper level clades until all clades are nested together in one large clade. This nested design was used as input for geographic distance analysis, which was used to examine the geographical distance within and between the clades. This was accomplished using the program GeoDis version 2.0 (Posada et al., 2000). This program examines the population structure as determined by geographical coordinates or pairwise distances and compares these values with the network created by TCS. The output is given as two main statistics; the clade distance (Dc), which measures the geographical spread within a clade, and the nested clade distance (Dn), which measures the geographical spread of a clade relative to other clades at the same nesting level. An interior-tip statistic (I-T) is also calculated, which calculates the average interior distance minus the average tip distance within each nested category.

TABLE 2. Variable sites and indels found within 807 bp and 747 bp fragments of the mitochondrial ND4 and d-loop markers, respectively. These sites define 11 haplotypes and their distribution across eight populations of *Eumeces septentrionalis* (refer to Figure 3 for population distribution). The most common haplotype, a, is used as a reference and dots indicate identity. Codon positions within the coding ND4 gene are given under the variable site positions. Indel positions within d-loop are represented by "0" for the absence of nucleotides and "1" for the presence of nucleotides. Haplotype "s" (southern population) was omitted because of the large number of variable sites.

	Variable sites and indels											Population								
	(ND4)					(d-loop)														
	Nucleotide position:	115	367	594	691	794	26	558	616	688	720	723	1	2	3	4	5	6	7	8
Codon position:	3	3	1	3	2	-	-	-	-	-	-	1	2	3	4	5	6	7	8	
Haplotypes																				
a	g	a	t	c	a	a	t	0	1	g	c	21	-	5	5	-	9	-	-	-
b	g	.	0	1	.	.	1	-	-	2	-	-	3	-	-
c	a	0	1	.	.	-	-	-	4	-	-	-	-	-
d	0	1	.	.	-	2	-	-	-	-	-	-	-
e	0	1	.	.	2	-	-	-	-	-	-	-	-
f	.	c	.	a	.	g	.	0	1	.	.	2	-	-	-	-	-	-	-	-
g	.	.	c	.	.	g	.	0	1	.	.	-	-	-	-	-	-	-	-	1
h	a	.	.	.	g	g	.	0	1	a	t	-	-	-	-	1	-	-	-	-
i	a	.	.	.	g	.	c	0	1	a	t	-	-	-	-	1	-	-	-	-
j	0	0	.	.	1	-	-	-	-	-	-	-	-
k	1	1	.	.	-	-	-	1	-	-	-	-	-

Phylogenetic Analysis.—The outgroup *E. obsoletus* was chosen based on a partial phylogenetic hypothesis for North American *Eumeces* (Richmond and Reeder, 2002). Maximum parsimony and maximum likelihood analyses were implemented in PAUP* (Swofford, 2001). For all analyses, taxon ordering was randomized to avoid order biases, and the tree bisection-reconstruction (TBR) branch-swapping method was implemented. Both parsimony and maximum likelihood trees were constructed using unweighted data. However, a transition:transversion (ti:tv) ratio bias has been well documented in past studies (Brown et al., 1982; Knight and Mindell, 1993), and maximum likelihood was used to estimate the ti/tv ratio of 3.6 for use in weighted analyses. Parsimony nonparametric bootstrapping values (100 pseudoreplicates) were used to determine nodal support for all resulting hypotheses (Felsenstein, 1985; Hillis and Bull, 1993).

RESULTS

A total of 807 nucleotides were aligned for ND4 of which 113 were variable and all were parsimony informative. Of the variable ND4 sites, 21 were found in the first codon position, four in the second, and 88 in the third. A total of 935 nucleotides were aligned (with gaps) for d-loop of which 96 were variable and 93 were parsimony informative. The 5' end of amplified d-loop fragment was conserved and the majority of variation found was within the last 350 bp of the

3' region. Several repeating motifs were also associated with the variable 3' region. A total of 747 nucleotides were aligned for d-loop of which 96 were variable and 93 were parsimony informative. d-loop also contained an additional 12 indel events, of which 10 were parsimony informative. DNA sequences are deposited in genbank (accession numbers: AY550555–AY550688).

The partition homogeneity test implemented in PAUP* (Swofford, 2001) failed to detect significant heterogeneity among the two data partitions indicating that they could be combined in a single dataset ($P = 0.55$). Results given hereafter represent the combined dataset.

Nested Clade Analysis.—Twelve different haplotypes were found among the 64 concatenated ND4/d-loop sequences. Ten of these haplotypes were only found at single localities and only two haplotypes (a and b) were found at multiple sites. Haplotype "a" was by far the most frequent with 40 (63%) individuals and was found in Manitoba, Minnesota, and North Dakota. Haplotype "b" was the second most frequent with five (8%) individuals and was found in Manitoba, North Dakota, and South Dakota. The Manitoba population exhibited the greatest number of haplotypes, five (42%), but it also comprised the largest sample size with 27 (42%) individuals. The North Dakota and Sacred Heart, MN populations contained the second and third largest sample sizes, and these populations contained four and one haplotypes respectively. Wisconsin was the only other population with more than one

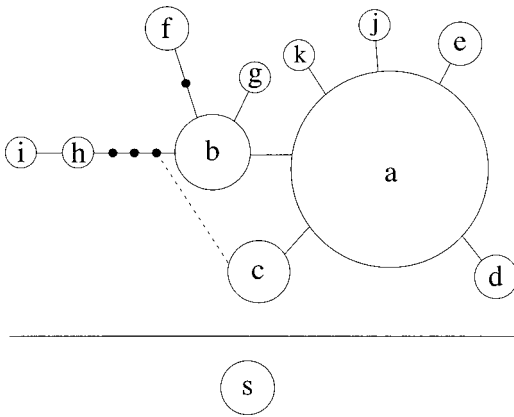

FIG. 2. Network for combined ND4/d-loop haplotypes observed in nine populations of *Eumeces septentrionalis*. Large sequence divergences left the southern haplotype "s" unconnected from the northern network. Two equally parsimonious paths resulted in one ambiguous closed loop. Phylogenetic analysis resolved this ambiguity and the less parsimonious path is shown with a dotted line.

haplotype and contained two haplotypes (Table 2, Figs. 1C and 2).

The haplotype network constructed by TCS (v. 1.0.3) detected two main clades representing the northern and southern populations. All individuals within the southern clade were genetically identical and were denoted by haplotype "s." The northern clade contained four subclades, and the nested design used for geographic distance analysis is shown in Figure 3.

Geographic distance analysis found significant distance values within two of the one-step clades, clade 1-1 and clade 1-2. Distance values for Clade 1-1 were significantly small for both clade (Dc) and nested clade (Dn) and clade 1-2 also exhibited significantly small clade (Dc) distance values (Fig. 4). Using the upgraded version of Templeton's inference key (1998), these significant values inferred restricted gene flow with isolation by distance between the clades and the haplotypes within them (Table 3). The same inference was made at the zero step level where haplotypes "a," "c," and "d" showed significant distance values. Geographic distance values for clade "a" were found to be significantly large for both clade and nested clade, and significantly small distance values were found for haplotypes "c" and "d." The average geographical distance between the tip and interior of these haplotypes (I-T) was also significantly large (Fig. 4).

The TCS network contained one closed loop formed by haplotypes b, c, and h. Closed loops are formed in places with equally parsimonious linkages between two or more haplotypes, and these loops may represent homoplasy (Templeton

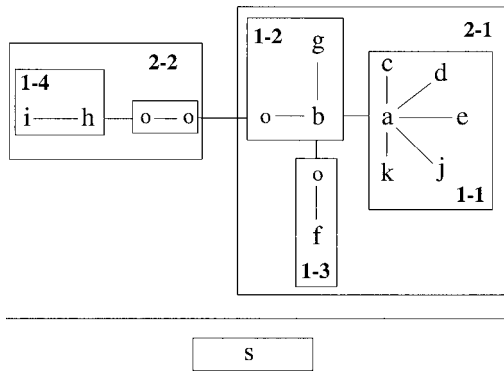

FIG. 3. Nested clade design for 12 haplotypes observed in nine populations of *Eumeces septentrionalis*. Each line represents one transitional step, and missing haplotypes are represented by the letter "o." Haplotypes "a-k" depict the northern populations of *E. septentrionalis*, and haplotype "s" represents the southern population found in Kansas. There are multiple transitional steps separating the northern populations from the southern Kansas population, and this large break is designated by a long, horizontal line separating the two.

and Sing, 1993). This parsimony ambiguity was resolved using a maximum likelihood phylogenetic analysis, which grouped haplotype "h" closer to haplotype "b" rather than "c" based on log likelihood score (Figs. 5 and 6).

Phylogenetic Analysis.—A total of 1566 characters for 64 individuals of *E. septentrionalis* and three individuals of *E. obsoletus* (outgroup) were used in the phylogenetic analysis. Of these, 221 were variable and 216 were parsimony informative. Parsimony analysis produced six equally parsimonious trees. Maximum likelihood, weighted and unweighted, supported one of these trees and it is shown in Figure 5. The reciprocal monophyly of *E. s. septentrionalis* and *E. s. obtusirostris* was strongly supported by both maximum parsimony (bootstrap = 100) and maximum likelihood analyses. Pairwise distance values between the northern and southern subspecies were also quite large and ranged from 6.7–7.0% (distance matrix available from the corresponding author on request). These values were comparatively higher than those within the northern subspecies, 0.06–0.38%. All three individuals from the southern subspecies had identical nucleotide sequences. Bootstrap values from parsimony analysis also provided strong support for some of the haplotypes in Manitoba (bootstrap = 89) and Wisconsin (bootstrap = 96).

DISCUSSION

Population Structure of Northern Populations.—We hypothesized four possible patterns of genetic structure for *E. septentrionalis* populations in

0-Step	a	c	d	e	j	k	b	g	f
D _c :	195 ^L	0 ^S	0	0	0	0	108	0	
D _n :	195 ^L	74 ^S	73 ^S	342	342	74	102	93	
(Int-Tip) _c :			195 ^L				108		
(Int-Tip) _n :			40				9		
1-Step				1-1				1-2	1-3
D _c :				162				98	0
D _n :				203				293	446
(Int-Tip) _c :								-59	
(Int-Tip) _n :								81	

FIG. 4. Nested clade distance analysis of ND4/d-loop haplotypes observed in eight populations of *Eumeces septentrionalis*. Haplotypes are given at the 0-step level. Under the name of any given clade are the clade (Dc) and nested clade (Dn) distances. The average interior versus tip (Int-Tip) differences are also given for both distance measures.

previously glaciated areas (Avice, 2000). First, populations exhibit low haplotype diversity and low haplotype divergence. This pattern would result if colonization was from a single source, and there is low gene flow between source and colonizing populations. Second, populations exhibit low haplotype diversity and moderate haplotype divergence. This pattern would result if colonization was from multiple, genetically distinct source populations, and there is low gene flow. Third, populations exhibit moderate haplotype diversity and low haplotype divergence. This pattern would result if colonization was from a single source, and there is moderate gene flow. Finally, populations exhibit moderate haplotype diversity and moderate haplotype divergence. This pattern would result if colonization was from multiple, genetically distinct source populations, and there is moderate gene flow. We do not expect to find high levels of haplotype diversity or haplotype divergence for two reasons. First, we expect the low vagility of *Eumeces* to limit gene flow. These skinks were found by Bredin (1981) to move less than 5 m from their burrow, and similar patterns of low dispersal have been reported for other North American *Eumeces* (Fitch, 1954). Second, we expect limited in situ postcolonization mutation. The last glacial retreat was 10,000–12,000 ybp (Holman, 1992), and current molecular clocks for vertebrate ectotherm mtDNA suggest divergence rates of 0.4–0.6% per Myrs (Rand, 1994; Coccone et al., 1999).

Eumeces septentrionalis in postglacier regions have moderate levels of haplotype diversity (20%; 12 haplotypes for 61 individuals sampled) and

low levels of haplotype divergence (0.06–0.38%). Nested clade analyses found isolation by distance to be the inferred pattern at the haplotype and upper clade levels as identified by the lack of overlapping haplotypes, indicating restricted gene flow consistent with ecological estimates of *E. septentrionalis* vagility. These results support the third pattern listed above and suggest that *E. septentrionalis* colonization into previously glaciated areas was from a single source with moderate gene flow. Postcolonization in situ mutations may account for additional levels of haplotype diversity, but we expect this addition to haplotype diversity to be limited. These results do not support past population fragmentation or colonization from multiple, genetically distinct source populations. *Eumeces septentrionalis* fossils in Walworth County, South Dakota, dating from the Pleistocene are found along the edge of the Laurentide Ice Sheet's furthest extent, and *E. septentrionalis* does not occur in this region today. The closest localities within the current distribution are 110 miles to the East. These fossils, along

TABLE 3. Inference chain from nested clade distance analysis shown in Figure 4 (Templeton, 1998).

Clade	Chain of inference	Inferred pattern
1-1	1-2a-3-4-No	Restricted gene flow with isolation by distance
1-2	No	N/A
1-4	No	N/A
2-1	1-2-3-4-No	Restricted gene flow with isolation by distance

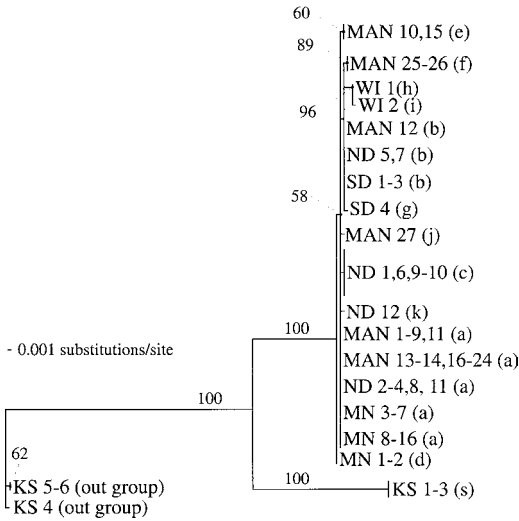

FIG. 5. Phylogeny of *Eumeces septentrionalis* as inferred from maximum-likelihood analysis. Individuals KS1, KS2, and KS3 represent *Eumeces septentrionalis obtusirostris*, and individuals KS4, KS5, and KS6 represent the outgroup *Eumeces obsoletus*. All other individuals shown represent *Eumeces septentrionalis septentrionalis*. Locality information (state or province) is given for each individual, and haplotypes are shown parenthetically. Bootstrap values shown are from maximum parsimony analysis (100 pseudoreplicates). Bootstrap values < 50% are not shown.

with the results found in this study, suggest a southwest shift in a contiguous population of *E. septentrionalis* during glacier advance as opposed to a strict southern shift or fragmentation (Holman, 1977).

Results similar to those found here were encountered by Austin et al. (2002) for frogs (*Pseudacris crucifer* 24%; 24 haplotypes for 98 individuals sampled) in regions previously glaciated by the Laurentide Ice Sheet. Low haplotype divergence was also found, and the authors suggest that the low haplotype diversity and low haplotype divergence is indicative of colonization from a single source.

Sampling success was unequal across collection localities, and we do not have adequate information to quantitatively assess comparative haplotype diversity. Qualitatively, the Manitoba population (#1) contained the largest number of haplotypes (five) along with largest sample size ($N = 27$). The North Dakota population (#4) contained four haplotypes and had less than half the sample size ($N = 12$) of the Manitoba population (#1). Populations in Minnesota (#2, #3, #6) and South Dakota (#7, #8) all consisted of one haplotype and had sample sizes of two, five, nine, three, and one, respectively. The Wisconsin population (#5) consisted of two haplotypes ($N =$

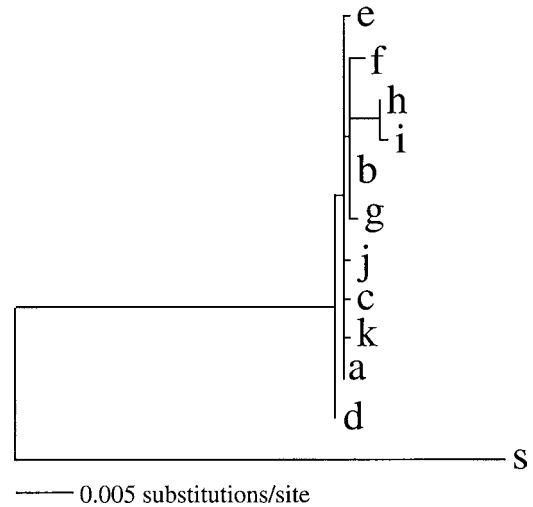

FIG. 6. Phylogeny of *Eumeces septentrionalis* haplotypes as inferred from maximum-likelihood analysis. Haplotypes "a-k" represent *Eumeces septentrionalis septentrionalis*, and haplotype "s" represents *Eumeces septentrionalis obtusirostris*. Individuals associated with each haplotype are shown in Figure 5.

2) that were four and five mutational steps away from the other populations of *E. s. septentrionalis*, and this moderate haplotype divergence may be indicative of a second source population into previously glaciated regions. The Wisconsin population occurs on the edge of the Laurentide Ice Sheet in a gap between the two lobes. The possibility of this population acting as a second source population is supported by its high haplotype diversity and the lack of overlapping haplotypes between the this population and other populations of *E. s. septentrionalis*. Nested clade analysis, however, did not identify the Wisconsin population as resulting from historical fragmentation. Further sampling would clarify the historical relationship between the Wisconsin population and the other northern populations.

Taxonomic Considerations.—The secretive nature of North American *Eumeces* combined with the morphological conservatism at the generic level has impeded a comprehensive phylogenetic analysis of this genus. A partial phylogeny using genetic data was constructed by Richmond and Reeder (2002), but they examined only 10 of the 23 species of North American *Eumeces*. The current subspecific taxonomy of *E. septentrionalis* is based on morphological differences described by Taylor (1935) and the allopatric distribution of the northern and southern populations. Taylor used four morphological traits to distinguish between the northern and southern forms. The first trait was based on the frontonasal scale contacting or not contacting the anterior loreal on each side. The two scales do not usually contact

within individuals of the northern form but are usually found to contact within the southern form. This trait is polymorphic, however, and both character states are found in the northern and southern populations. The remaining three characters described by Taylor to distinguish between the northern and southern forms are based on color and pattern. The northern form usually has a light ground color, has present, but frequently poorly defined, dark borders on both sides of the median light line, and has well-defined dark lines bordering the dorsolateral light lines. These characteristics contrast with those of the southern form, which has a dark ground color, no dark border along the median light line, and poorly defined dark lines bordering the dorsolateral light lines. Unfortunately, these traits are not easily quantifiable and do not provide a distinct method for distinguishing between the two forms. This has resulted in inconsistency in the literature over their placement as one or two species.

Our genetic data demonstrate reciprocal monophyly between the northern and southern forms. These results are strongly supported (bootstrap = 100) by both maximum parsimony and maximum likelihood analyses. Sequence divergence between the two forms were 6–7% and suggest that the northern and southern forms have existed in allopatry with little to no gene flow between them. The limited sampling for *E. s. obtusirostris* does not allow further inferences to be made between the northern and southern forms. These results agree with morphological differences and allopatry of the two species, however, and suggest that the northern and southern forms may be on separate evolutionary trajectories. Further genetic work with increased sampling will help to elucidate the pattern of evolutionary history within *E. septentrionalis*.

Acknowledgments.—Funding for this project was provided by the National Science Foundation DBI 0115985, the University of North Dakota, a University of North Dakota APSAC, and the Wildlife Branch of Manitoba Conservation. We are grateful to the following people for input and comments of this project: E. Bredin, A. Gerber, J. La Duke, and J. Lang. We thank the numerous museums that provided access to their locality information, including Texas A&M University; Field Museum of Natural History; Bell Museum; Natural History Museum of Los Angeles County; Carnegie Museum of Natural History; University of Nebraska State Museum; Museum of Natural History; Museum of Vertebrate Zoology; and University of Texas at Arlington. Special thanks go to J. Lang, R. Sweitzer, B. Bly, and the Museum of Natural Science at Louisiana State University

for providing some tissue samples for this project. We are also grateful to the many private land-owners that provided access to their land.

LITERATURE CITED

- AUSTIN, J. D., S. C. LOUGHEED, L. NEIDRAUER, A. A. CHEK, AND P. T. BOAG. 2002. Cryptic lineages in a small frog: the post-glacial history of the Spring Peeper, *Pseudacris crucifer* (Anura: Hylidae). *Molecular Phylogenetics and Evolution* 25:316–329.
- AVISE, J. C. 2000. *Phylogeography: The History and Formation of Species*. Harvard Univ. Press, Cambridge, MA.
- BENABIB, M., K. M. KJER, AND J. W. SITES. 1997. Mitochondrial DNA sequence-based phylogeny and the evolution of viviparity in the *Sceloporus scalaris* (Reptilia, Squamata). *Evolution* 51:1262–1275.
- BRECKENRIDGE, W. J. 1943. The life history of the Black-Banded Skink *Eumeces septentrionalis septentrionalis* (Baird). *American Midland Naturalist* 29:591–606.
- BREDIN, E. J. 1981. Distribution of the Northern Prairie Skink in Manitoba, pp. 1–27. Manitoba Department of Natural Resources: Wildlife Branch, Winnipeg, Manitoba, Canada.
- BROWN, W. M., E. M. PRAGER, A. WANG, AND A. C. WILSON. 1982. Mitochondrial DNA sequences of primates: tempo and mode of evolution. *Journal of Molecular Evolution* 18:255–239.
- BURBRINK, F. T., R. LAWSON, AND J. B. SLOWINSKI. 2000. Mitochondrial DNA phylogeography of the polytypic North American Rat Snake (*Elaphe obsoleta*): a critique of the subspecies concept. *Evolution* 54:2107–2118.
- CLEMENT, M., D. POSADA, AND K. A. CRANDALL. 2000. TCS: a computer program to estimate gene genealogies. *Molecular Ecology* 9:1657–1659.
- COCCONE, A., G. AMATO, O. C. GRATRY, J. BEHLER, AND J. R. POWELL. 1999. A molecular phylogeny of four endangered Madagascar tortoises based on mtDNA sequences. *Molecular Phylogenetics and Evolution* 12:1–9.
- COLLINS, J. T. 1993. *Amphibians and Reptiles in Kansas*. Univ. of Kansas, Lawrence.
- CONANT, R., AND J. T. COLLINS. 1998. *Reptiles and Amphibians: Eastern/Central North America*. Houghton Mifflin Co., Boston, MA.
- CROTHER, B. I. 2000. Scientific and standard English names of amphibians and reptiles of North America north of Mexico, with comments regarding confidence in our understanding. *Herpetological Circular* 29:1–82.
- FELSENSTEIN, J. 1985. Confidence limits on phylogenies: an approach using the bootstrap. *Evolution* 39:783–791.
- FITCH, H. S. 1954. Life history and ecology of the Five-Lined Skink, *Eumeces fasciatus*. Univ. of Kansas Publications, Museum of Natural History 8:1–156.
- FLINT, R. F. 1971. *Glacial and Quaternary Geology*. John Wiley and Sons, New York.
- FORSTNER, M. R. J., J. R. DIXON, J. M. FORSTNER, AND S. K. DAVIS. 1998. Apparent hybridization between *Cnemidophorus gularis* and *Cnemidophorus septemvittatus* from an area of sympatry in southwest Texas. *Journal of Herpetology* 32:418–425.

- FUTUYMA, D. J. 1998. *Evolutionary Biology*. Sinauer Associates, Inc., Sunderland, MA.
- GERBER, A. S., AND A. R. TEMPLETON. 1996. Population sizes and within-deme movement of *Trimerotropis saxatilis* (Acrididae), a grasshopper with a fragmented distribution. *Oecologia* 105:343–350.
- HEWITT, G. W. 1996. Some genetic consequences of ice ages, and their role in divergence and speciation. *Biological Journal of the Linnean Society* 58:247–276.
- HILLIS, D. M., AND J. J. BULL. 1993. An empirical test of bootstrapping as a method for assessing confidence in phylogenetic analysis. *Systematic Biology* 42:182–192.
- HOLMAN, J. A. 1977. America's northernmost Pleistocene herpetofauna (Java, north-central South Dakota). *Copeia* 1977:191–193.
- . 1992. Late Quaternary herpetofauna of the central Great Lakes region, U.S.A.: zoogeographical and paleoecological implications. *Quaternary Science Reviews* 11:345–351.
- HUDSON, R. R. 1989. How often are polymorphic restriction sites due to single mutation? *Theoretical Population Biology* 36:23–33.
- HUMPHRIES, C. J., AND L. R. PARENTI. 1986. *Cladistic Biogeography*. Clarendon Press, Oxford.
- KEOGH, S. J., I. A. W. SCOTT, M. FITZGERALD, AND R. SHINE. 2003. Molecular phylogeny of the Australian venomous snake genus *Hoplocephalus* (Serpentes, Elapidae) and conservation genetics of the threatened *H. stephensii*. *Conservation Genetics* 4:57–65.
- KNIGHT, A., AND D. P. MINDELL. 1993. Substitution bias, weighting of DNA sequence evolution, and the phylogenetic position of Fea's viper. *Systematic Biology* 42:18–31.
- KUMAZAWA, Y., AND M. NISHIDA. 1999. Complete mitochondrial DNA sequences of the Green Turtle and Blue-Tailed Mole Skink: statistical evidence for archosaurian affinity of turtles. *Molecular Biology and Evolution* 16:784–792.
- LANG, J. W. 1982. Distribution and abundance of the Five-Lined Skink (*Eumeces fasciatus*) in Minnesota, pp. 1–41. Minnesota Department of Natural Resources, Wildlife Section, St. Paul.
- MATSCH, C. L. 1976. *North America and the Great Ice Age*. McGraw-Hill, New York.
- NELSON, G. J., AND N. I. PLATNICK. 1981. *Systematics and Biogeography: Cladistics and Vicariance*. Columbia Univ. Press, New York.
- NELSON, G. J., AND D. E. ROSEN. 1981. *Vicariance Biogeography: A Critique*. Columbia Univ. Press, New York.
- NELSON, W. F. 1963. Natural History of the Northern Prairie Skink, *Eumeces septentrionalis septentrionalis* (Baird), p. 134. Univ. of Minnesota, Minneapolis.
- PALUMBI, S. R. 1996. Nucleic acids II: the polymerase chain reaction. In D. M. Hillis, C. Moritz, and B. K. Mable (eds.), *Molecular Markers*, pp. 205–247. Sinauer Associates, Inc., Sunderland, MA.
- PHILLIPS, C. A. 1994. Geographic distribution of mitochondrial DNA variants and the historical biogeography of the Spotted Salamander, *Ambystoma maculatum*. *Evolution* 48:597–607.
- POSADA, D., K. A. CRANDALL, AND A. R. TEMPLETON. 2000. GeoDis: a program for the cladistic nested analysis of the geographical distribution of genetic haplotypes. *Molecular Ecology* 9:487–488.
- RAND, D. M. 1994. Thermal habit, metabolic rate, and the evolution of mitochondrial DNA. *Trends in Ecology and Evolution* 9:125–131.
- RICHMOND, J. Q., AND T. W. REEDER. 2002. Evidence for parallel ecological speciation in Scincid lizards of the *Eumeces skiltonianus* species group (Squamata: Scincidae). *Evolution* 56:1498–1513.
- ROUTMAN, E., R. WU, AND A. R. TEMPLETON. 1994. Parsimony, molecular evolution, and biogeography: the case of the North American giant salamander. *Evolution* 48:1799–1809.
- RUSSO, C. A. M., N. TAKEZAKI, AND M. NEI. 1996. Efficiencies of different genes and different tree-building methods in recovering a known vertebrate phylogeny. *Molecular Biology and Evolution* 13:525–536.
- SCOTT, T. G., AND R. B. SHELD AHL. 1937. Black-Banded Skink in Iowa. *Copeia* 1937: 192.
- SMITH, H. M., AND J. A. SLATER. 1949. The southern races of *Eumeces septentrionalis* (Baird). *Transactions of the Kansas Academy of Science* 52:438–448.
- STARKEY, D. E., SHAFFER, H. B., BURKE, R. L., FORSTNER, R. J., IVERSON, J. B., JANSEN, F. J., RHODIN, G. J., AND R. R. ULTSCH. 2003. Molecular systematics, phylogeography, and the effects of Pleistocene glaciation in the Painted Turtle (*Chrysemys picta*) complex. *Evolution* 57:119–128.
- SWOFFORD, D. L. 2001. PAUP*: Phylogenetic analysis using parsimony (*and other methods). Sinauer Associates, Sunderland, MA.
- TAYLOR, E. H. 1935. A taxonomic study of the cosmopolitan scincoid lizards of the genus *Eumeces* with an account of the distribution and relationships of its species. *Kansas Univ. Science Bulletin* 23:1–643.
- TEMPLETON, A. R. 1998. Nested clade analyses of phylogeographic data: testing hypotheses about gene flow and population history. *Molecular Ecology* 7:381–397.
- TEMPLETON, A. R., AND C. F. SING. 1993. A cladistic analysis of phenotypic associations with haplotypes inferred from restriction endonuclease mapping. IV. Nested analyses with cladogram uncertainty and recombination. *Genetics* 134:659–669.
- TEMPLETON, A. R., E. BOERWINKLE, AND C. F. SING. 1987. A cladistic analysis of phenotypic associations with haplotypes inferred from restriction endonuclease mapping. I. Basic theory and an analysis of alcohol dehydrogenase activity in *Drosophila*. *Genetics* 117:343–351.
- TEMPLETON, A. R., K. A. CRANDALL, AND C. F. SING. 1992. A cladistic analysis of phenotypic associations with haplotypes inferred from restriction endonuclease mapping and DNA sequence data. III. Cladogram estimation. *Genetics* 132:619–633.
- TEMPLETON, A. R., E. ROUTMAN, AND C. A. PHILLIPS. 1995. Separating population structure from population history: a cladistic analysis of the geographical distribution of mitochondrial DNA haplotypes in the tiger salamander, *Ambystoma tigrinum*. *Genetics* 140:767–782.
- THOMPSON, J. D., T. J. GIBSON, F. PLEWNIAC, F. JEANMOUGIN, AND D. G. HIGGINS. 1997. The clustal X windows interface: flexible strategies for multiple sequence alignment aided by quality analysis tools. *Nucleic Acids Research* 24:4876–4882.

- WHEELER, G. C., AND J. WHEELER. 1966. The Amphibians and Reptiles of North Dakota. Univ. of North Dakota Press, Grand Forks.
- ZARDOYA, R., AND A. MEYER. 1996. Phylogenetic performance of mitochondrial protein-coding genes in resolving relationships among vertebrates. *Molecular Biology and Evolution* 13:933–942.

Accepted: 2 March 2004.

APPENDIX 1. Locality information arranged north to south for 64 *Eumeces septentrionalis* and three *Eumeces obsoletus*.

Sample	Accession/tissue number	Species	County	State	Country
MAN1	no voucher (CCA7024)	<i>Eumeces septentrionalis</i>	North Cypress	Manitoba	Canada
MAN2	no voucher (CCA 7023)	<i>Eumeces septentrionalis</i>	North Cypress	Manitoba	Canada
MAN3	no voucher (CCA 7026)	<i>Eumeces septentrionalis</i>	North Cypress	Manitoba	Canada
MAN4	no voucher (CCA 7020)	<i>Eumeces septentrionalis</i>	North Cypress	Manitoba	Canada
MAN5	LSUMZ 87754	<i>Eumeces septentrionalis</i>	North Cypress	Manitoba	Canada
MAN6	no voucher (CCA 7022)	<i>Eumeces septentrionalis</i>	North Cypress	Manitoba	Canada
MAN7	no voucher (CCA 7021)	<i>Eumeces septentrionalis</i>	North Cypress	Manitoba	Canada
MAN8	no voucher (GSF 069)	<i>Eumeces septentrionalis</i>	North Cypress	Manitoba	Canada
MAN9	LSUMZ 87756	<i>Eumeces septentrionalis</i>	North Cypress	Manitoba	Canada
MAN10	no voucher (CCA 7013)	<i>Eumeces septentrionalis</i>	South Cypress	Manitoba	Canada
MAN11	LSUMZ 87753	<i>Eumeces septentrionalis</i>	South Cypress	Manitoba	Canada
MAN12	no voucher (CCA 7019)	<i>Eumeces septentrionalis</i>	South Cypress	Manitoba	Canada
MAN13	no voucher (CCA 7016)	<i>Eumeces septentrionalis</i>	South Cypress	Manitoba	Canada
MAN14	no voucher (CCA 7015)	<i>Eumeces septentrionalis</i>	South Cypress	Manitoba	Canada
MAN15	no voucher (CCA 7014)	<i>Eumeces septentrionalis</i>	South Cypress	Manitoba	Canada
MAN16	LSUMZ 87761	<i>Eumeces septentrionalis</i>	South Cypress	Manitoba	Canada
MAN17	LSUMZ 87750	<i>Eumeces septentrionalis</i>	South Cypress	Manitoba	Canada
MAN18	LSUMZ 87749	<i>Eumeces septentrionalis</i>	South Cypress	Manitoba	Canada
MAN19	LSUMZ 87748	<i>Eumeces septentrionalis</i>	South Cypress	Manitoba	Canada
MAN20	LSUMZ 87758	<i>Eumeces septentrionalis</i>	South Cypress	Manitoba	Canada
MAN21	LSUMZ 87757	<i>Eumeces septentrionalis</i>	South Cypress	Manitoba	Canada
MAN22	LSUMZ 87760	<i>Eumeces septentrionalis</i>	South Cypress	Manitoba	Canada
MAN23	LSUMZ 87763	<i>Eumeces septentrionalis</i>	South Cypress	Manitoba	Canada
MAN24	LSUMZ 87759	<i>Eumeces septentrionalis</i>	South Cypress	Manitoba	Canada
MAN25	no voucher (CCA 7012)	<i>Eumeces septentrionalis</i>	South Cypress	Manitoba	Canada
MAN26	LSUMZ 87764	<i>Eumeces septentrionalis</i>	South Cypress	Manitoba	Canada
MAN27	LSUMZ 87762	<i>Eumeces septentrionalis</i>	South Cypress	Manitoba	Canada
MN1	LSUMZ 87768	<i>Eumeces septentrionalis</i>	Polk	MN	USA
MN2	LSUMZ 87773	<i>Eumeces septentrionalis</i>	Polk	MN	USA
MN3	no voucher (CCA 7033)	<i>Eumeces septentrionalis</i>	Clearwater	MN	USA
MN4	no voucher (CCA 7032)	<i>Eumeces septentrionalis</i>	Clearwater	MN	USA
MN5	no voucher (CCA 7031)	<i>Eumeces septentrionalis</i>	Clearwater	MN	USA
MN6	no voucher (CCA 7029)	<i>Eumeces septentrionalis</i>	Clearwater	MN	USA
MN7	no voucher (CCA 7028)	<i>Eumeces septentrionalis</i>	Clearwater	MN	USA
ND1	no voucher (CCA 7035)	<i>Eumeces septentrionalis</i>	Ransom	ND	USA
ND2	LSUMZ 87765	<i>Eumeces septentrionalis</i>	Ransom	ND	USA
ND3	LSUMZ 87745	<i>Eumeces septentrionalis</i>	Ransom	ND	USA
ND4	no voucher (CCA 7000)	<i>Eumeces septentrionalis</i>	Ransom	ND	USA
ND5	LSUMZ 87766	<i>Eumeces septentrionalis</i>	Ransom	ND	USA
ND6	LSUMZ 87746	<i>Eumeces septentrionalis</i>	Ransom	ND	USA
ND7	LSUMZ 87744	<i>Eumeces septentrionalis</i>	Ransom	ND	USA
ND8	no voucher (GSF 080)	<i>Eumeces septentrionalis</i>	Ransom	ND	USA
ND9	no voucher (GSF 079)	<i>Eumeces septentrionalis</i>	Ransom	ND	USA
ND10	LSUMZ 87767	<i>Eumeces septentrionalis</i>	Ransom	ND	USA
ND11	no voucher (GSF 085)	<i>Eumeces septentrionalis</i>	Ransom	ND	USA
ND12	no voucher (GSF 086)	<i>Eumeces septentrionalis</i>	Ransom	ND	USA
WI1	LSUMZ H1231	<i>Eumeces septentrionalis</i>	Eau Claire	WI	USA
WI2	LSUMZ H1230	<i>Eumeces septentrionalis</i>	Eau Claire	WI	USA
MN8	LSUMZ 87737	<i>Eumeces septentrionalis</i>	Renville	MN	USA
MN9	LSUMZ 87736	<i>Eumeces septentrionalis</i>	Renville	MN	USA
MN10	LSUMZ 87739	<i>Eumeces septentrionalis</i>	Renville	MN	USA
MN11	LSUMZ 87738	<i>Eumeces septentrionalis</i>	Renville	MN	USA
MN12	LSUMZ 87732	<i>Eumeces septentrionalis</i>	Renville	MN	USA

APPENDIX 1. Continued.

Sample	Accession/tissue number	Species	County	State	Country
MN13	LSUMZ 87730	<i>Eumeces septentrionalis</i>	Renville	MN	USA
MN14	LSUMZ 87729	<i>Eumeces septentrionalis</i>	Renville	MN	USA
MN15	LSUMZ 87728	<i>Eumeces septentrionalis</i>	Renville	MN	USA
MN16	LSUMZ 87731	<i>Eumeces septentrionalis</i>	Renville	MN	USA
SD1	LSUMZ 87709	<i>Eumeces septentrionalis</i>	Hanson	SD	USA
SD2	LSUMZ 87747	<i>Eumeces septentrionalis</i>	Hanson	SD	USA
SD3	LSUMZ 87710	<i>Eumeces septentrionalis</i>	Hanson	SD	USA
SD4	LSUMZ 87769	<i>Eumeces septentrionalis</i>	Union	SD	USA
KS1	no voucher (CCA 7005)	<i>Eumeces septentrionalis</i>	Clark	KS	USA
KS2	LSUMZ 87778	<i>Eumeces septentrionalis</i>	Clark	KS	USA
KS3	LSUMZ 87775	<i>Eumeces septentrionalis</i>	Clark	KS	USA
KS4	LSUMZ 87779	<i>Eumeces obsoletus</i>	Chase	KS	USA
KS5	no voucher (CCA 7006)	<i>Eumeces obsoletus</i>	Chase	KS	USA
KS6	LSUMZ 87780	<i>Eumeces obsoletus</i>	Chase	KS	USA